

A2302

N-Channel Enhancement Mode MOSFET



Pb-free

Features

- High performance trench technology
- Low ON-resistance
- 2.5V gate drive
- Low profile surface mount package
- Lead (Pb) free product

Product Summary

V _{DS} (V)	I _D (A)	R _{DS(ON)} (mΩ) Max
20V	2.4A	60 @V _{GS} = 4.5V
		115 @V _{GS} = 2.5V

Applications

- Load switch
- PWM application
- Power management

SOT-23

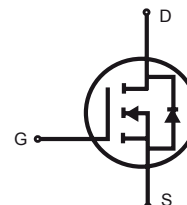
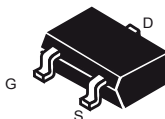

Absolute Maximum Ratings (T_A = 25°C unless otherwise noted)

Parameter	Symbol	Rating	Unit
Drain-Source Voltage	V _{DS}	20	V
Gate-Source Voltage	V _{GS}	± 8	V
Drain Current-Continuous @ T _C = 25°C	I _D	2.4	A
-Pulsed ^b	I _{DM}	10	A
Drain-Source Diode Forward Current ^a	I _S	0.9	A
Maximum Power Dissipation ^a	P _D	0.9	W
Operating Junction and Storage Temperature Range	T _J , T _{STG}	-55 to 150	°C

Thermal Characteristics

Thermal Resistance, Junction-to-Ambient ^a	R _{θJA}	115	°C/W
--	------------------	-----	------

Electrical Characteristics (TA = 25°C unless otherwise noted)

Parameter	Symbol	Condition	Min	Typ ^c	Max	Unit
Static						
Drain-Source Breakdown Voltage	BV _{DSS}	V _{GS} =0V, I _D =250 μA	20			V
Zero Gate Voltage Drain Current	I _{DSS}	V _{DS} =16V, V _{GS} =0V			1	μA
Gate-Body Leakage	I _{GSS}	V _{GS} =±8V, V _{DS} =0V			±100	nA
Gate Threshold Voltage	V _{GS(th)}	V _{DS} =V _{GS} I _D =250 μA	0.55		1.2	V
Drain-Source On-State Resistance	R _{DS(ON)}	V _{GS} =4.5V, I _D =3.6A		45	60	mΩ
		V _{GS} =2.5V, I _D =3.1A		80	115	
On-State Drain Current	I _{D(ON)}	V _{DS} =5V, V _{GS} =2.5V	4			A
Forward Transconductance	g _{FS}	V _{DS} =5V, I _D =3.6A		8		S
Diode Forward Voltage	V _{SD}	V _{GS} =0V, I _D =0.9A		0.8	1.2	V
Dynamic						
Input Capacitance	C _{ISS}	V _{DS} =15V V _{GS} =0V f=1.0MHz		300		pF
Output Capacitance	C _{OSS}			115		
Reverse Transfer Capacitance	C _{RSS}			75		
Turn-On Delay Time	t _{D(ON)}	V _D =10V, I _D =3.6A, V _{GEN} =4.5V, R _{GEN} =6Ω, R _L =2.8Ω		7		ns
Rise Time	t _r			55		
Turn-Off Delay Time	t _{D(OFF)}			15		
Fall Time	t _f			10		
Total Gate Charge	Q _g	V _{DS} =10V, I _D =3.6A, V _{GS} =4.5V		4	10	nC
Gate-Source Charge	Q _{gs}			0.7		
Gate-Drain Charge	Q _{gd}			1.6		

Notes:

- a. Surface Mounted on FR4 Board, t ≤ 10 sec.
- b. Pulse Test: Pulse Width ≤ 300 μs, Duty Cycle ≤ 2%.
- c. Guaranteed by design, not subject to production testing.

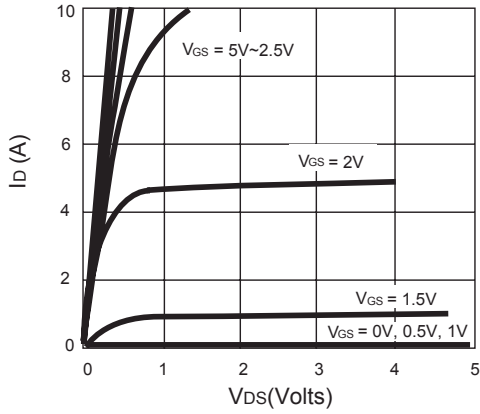

Figure 1. On-Regions Characteristics

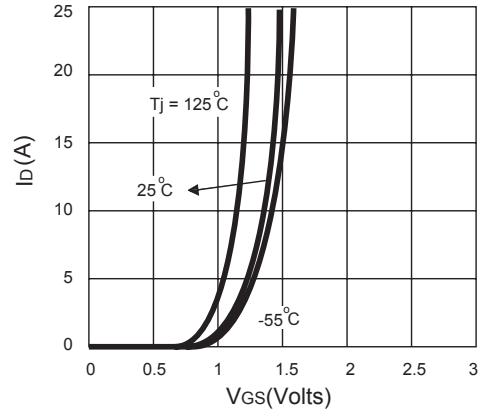

Figure 2. Transfer Characteristics

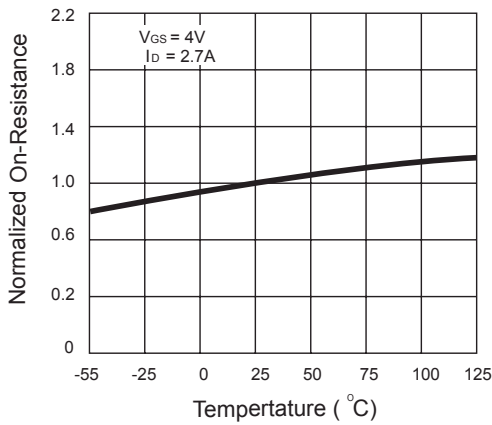

Figure 3. On-Resistance vs. Junction Temperature

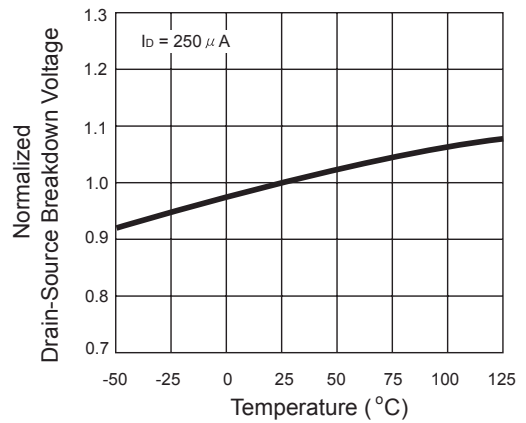

Figure 4. Drain-Source Breakdown Voltage vs. Temperature

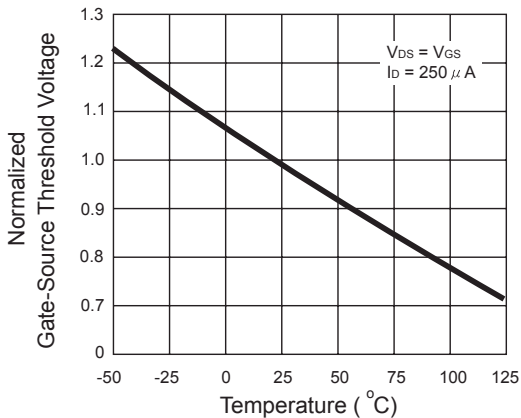

Figure 5. Gate Threshold vs Junction Temperature

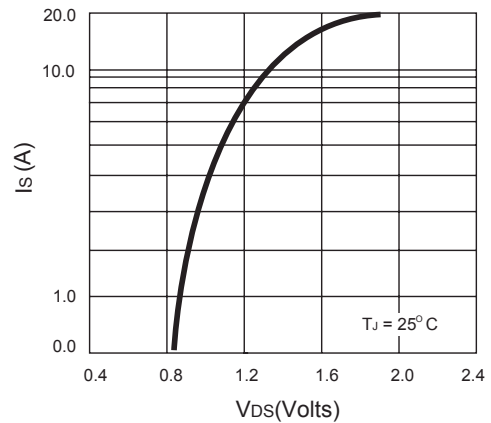

Figure 6. Body Diode Characteristics

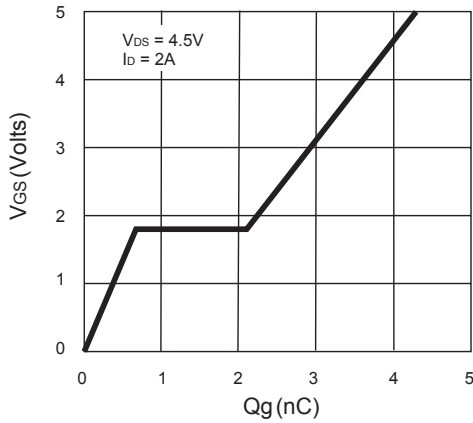

Figure 7. Gate-Charge Characteristics

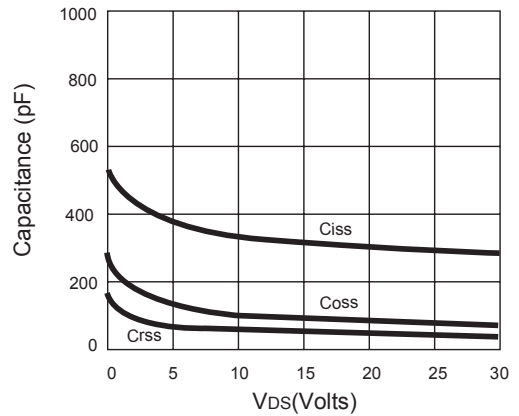

Figure 8. Capacitance Characteristics

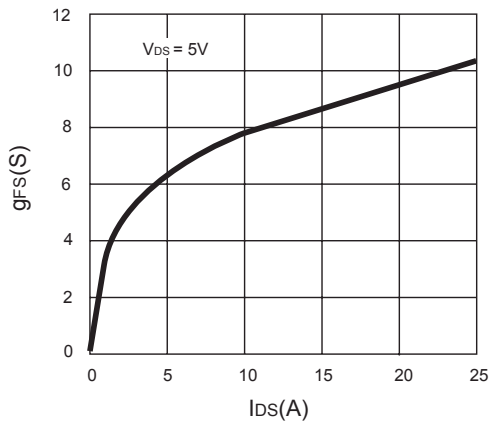

Figure 9. Transconductance vs. Drain Current

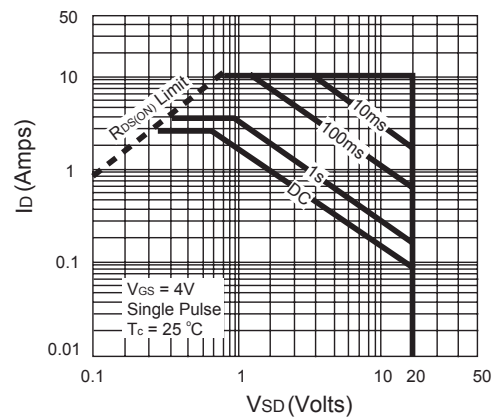

Figure 10. Maximum Forward Biased Safe Operating Area

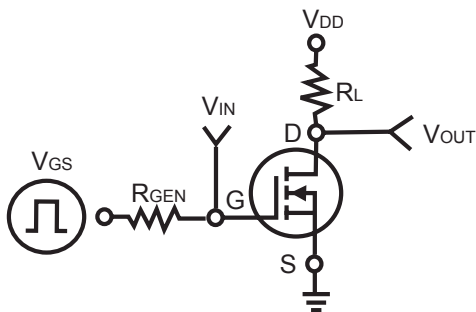

Figure 11. Switching Test Circuit

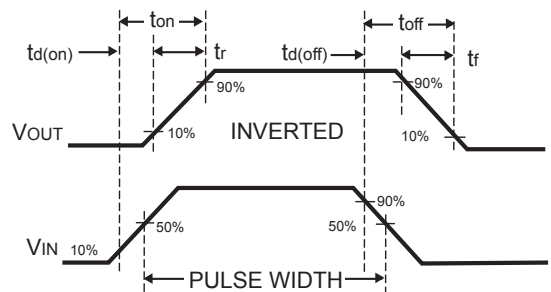

Figure 12. Switching Waveforms

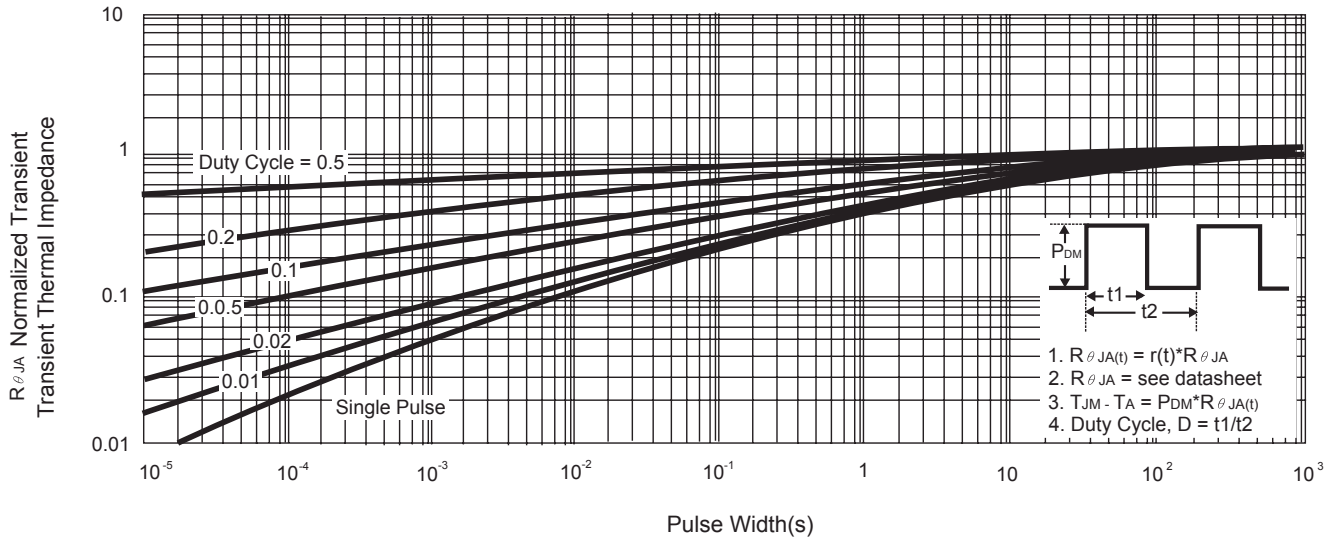

Figure 13. Normalized Maximum Transient Thermal Impedance